

2005

# Opportunistic maintenance policy of a multi-unit system under transient state

Sulabh Jain

*University of South Florida*

Follow this and additional works at: <http://scholarcommons.usf.edu/etd>



Part of the [American Studies Commons](#)

---

## Scholar Commons Citation

Jain, Sulabh, "Opportunistic maintenance policy of a multi-unit system under transient state" (2005). *Graduate Theses and Dissertations*.

<http://scholarcommons.usf.edu/etd/2934>

This Thesis is brought to you for free and open access by the Graduate School at Scholar Commons. It has been accepted for inclusion in Graduate Theses and Dissertations by an authorized administrator of Scholar Commons. For more information, please contact [scholarcommons@usf.edu](mailto:scholarcommons@usf.edu).

Opportunistic Maintenance Policy of a Multi-Unit System Under Transient State

by

Sulabh Jain

A thesis submitted in partial fulfillment  
of the requirements for the degree of  
Master of Science in Industrial Engineering  
Department of Industrial and Management Systems Engineering  
College of Engineering  
University of South Florida

Major Professor: O. Geoffrey Okogbaa, Ph.D.  
Tapas. K. Das, Ph.D.  
A.N.V. Rao, Ph.D.

Date of Approval:  
July 8, 2005

Keywords: failure-repair process, non-steady state, renewal theory, simulation, instantaneous availability, sensitivity analysis

© Copyright 2005, Sulabh Jain

## Table of Contents

List of Tables .....	iii
List of Figures .....	iv
Abstract .....	v
Chapter 1. Introduction .....	1
1.1 Background .....	1
1.2 Maintenance Strategies: Corrective Maintenance and Preventive Maintenance .....	2
1.3 Maintenance Dependency: Stochastic and Economical.....	3
1.4 Steady State Behavior versus Transient State Behavior .....	4
1.5 Availability Analysis .....	5
1.6 Research Objective .....	5
Chapter 2. Literature Review .....	7
2.1 Maintenance Policies .....	7
2.1.1 Preventive Maintenance Models.....	7
2.1.2 Opportunistic Maintenance Models.....	9
2.2 Renewal Theory Applications.....	10
2.3 Transient Behavior.....	12
2.4 Availability .....	15
Chapter 3. Problem Description.....	18
Chapter 4. Modeling Methodology.....	20
4.1 System Description and Assumptions .....	20
4.1.1 System Description .....	20
4.1.2 Assumptions.....	20
4.1.3 Notations.....	21
4.2 Failure and Repair Process.....	22
4.3 Steady State and Transient State Age Replacement Policy .....	23
4.3.1 Steady State Age Replacement Policy .....	24
4.3.2 Transient State Age Replacement Policy.....	25
4.3.2.1 Case 1.....	26
4.3.2.2 Case 2.....	27
4.4 Opportunistic Maintenance Policy.....	27
4.4.1 Preventive Maintenance Simulation Model.....	28
4.4.2 Opportunistic Maintenance Simulation Model.....	29
4.5 Availability Measure.....	31
Chapter 5. Results and Analysis .....	32

5.1 Failure Repair Process .....	32
5.1.1 Kolmogorov-Simrnov test .....	34
5.2 Transient State Preventive Replacement Model .....	37
5.3 Maintenance Model .....	39
5.3.1 Preventive Maintenance Policy.....	40
5.3.2 Opportunistic Maintenance Policy.....	40
5.3.3 Cost Comparison Between PMP and PMP.....	41
5.3.4 Sensitivity Analysis .....	42
5.4 Availability Analysis .....	43
Chapter 6. Conclusions and Future research.....	46
6.1 Future Research Direction .....	47
References.....	48

## List of Tables

Table 5.1 Lifetime Distribution Parameters of Four Components for the Aluminum Line.....	32
Table 5.2 Failure, Repair and Resultant Distribution Parameters for the System .....	33
Table 5.3 Data and Calculations for KS test.....	35
Table 5.4 Optimal Preventive Maintenance Interval for the Components (T = 5 Years) .....	39
Table 5.5 Preventive Maintenance Policy (T = 5 Years).....	40
Table 5.6 95% Confidence Interval for the Total Cost .....	40
Table 5.7 Opportunistic Maintenance Policy (T = 5 Years) .....	41
Table 5.8 95% Confidence Interval for the Total Cost .....	41
Table 5.9 Cost Comparison between PMP and OMP .....	41
Table 5.10 Sensitivity Analysis on Optimal Replacement Interval for PMP.....	42
Table 5.11 Sensitivity Analysis on Optimal Replacement Interval for OMP .....	42
Table 5.12 Comparison between PMP and OMP .....	43

## List of Figures

Figure 2.1 Expected Cost per unit Time over Finite Time Horizons versus Inspection Intervals .	13
Figure 2.2 Ten Component System .....	14
Figure 2.3 State Transition Diagram for Preventive Maintenance .....	15
Figure 4.1 Failure-Repair Process.....	22
Figure 4.2 Replacement Due to Failure ( $v < t_A$ ) .....	26
Figure 4.3 Replacement Due to PM ( $t_A < v$ ).....	26
Figure 5.1 Failure Times Plot for Weibull Distribution (0.41, 4.26).....	36
Figure 5.2 Repair Times Plot for Lognormal Distribution (0.353, 1.26).....	37
Figure 5.3 Resultant Failure + Repair Plot .....	37
Figure 5.4 Cost Structure for Components of the System .....	38
Figure 5.5 Optimal Replacement Intervals for the Components of the System.....	39
Figure 5.6 Comparison between Cost and Availability with Interval Width.....	44
Figure 5.7 3-D Plot of Availability versus Cost.....	45

## **Opportunistic Maintenance Policy of a Multi-unit System under Transient State**

Sulabh Jain

### **ABSTRACT**

Most modern systems are equipped with very complex, expensive, and high technology components whose maintenance costs have become an increasingly large portion of the total operating cost of these systems. Thus, the efficacy of the maintenance policy for these and related systems has become a major concern to both manufacturing and design engineers. Different kinds of maintenance strategies have been proposed to solve the problem. While some of these have proven effective, there is yet no definitive approach that has been found that support the maintainability requirements of transient systems or systems that exhibit transient behavior. Transient behavior is the notion of non-steady state operation, which is the characteristic of system operation during its useful life. For designing convenience most of the maintenance strategies have assumed negligible maintenance or repair time which is not practical.

In this research an opportunistic maintenance (OM) approach is implemented on a multi-unit system that exhibits transient behavior. Under OM policy, if a maintenance event has been scheduled for certain components and in the process of implementing the scheduled maintenance of these targeted components, the maintenance of other components whose maintenance times are in close proximity is also implemented at the same time. As a result, the time and cost of marshalling and staging maintenance resources are reduced. As part of the system effectiveness measure, the instantaneous system availability based on the transient nature of the system, is estimated using the renewal theory approach. An advantage of modeling system failure process

as a renewal process is that the system failure causes and the underlying probability structure associated the distributions are tracked and identified.

Using simulation, and assuming Weibull distribution failure times and lognormal distribution repairs or maintenance times, a cost model is developed that minimizes the overall maintenance cost of the system. This cost framework is then used to evaluate total maintenance costs incurred while implementing OM and PM policies. The optimal replacement times for the components of the system for the PM policy are obtained using analytical formulation. The results of the simulation model show that the OM policy is more economically viable as compared to the PM policy. A sensitivity analysis is performed to explore the robustness of the system parameters. The results of the sensitivity analyses show that the total system maintenance cost is lowest at optimal maintenance intervals for individual components. Furthermore, another measure of system effectiveness, the instantaneous availability of the system is estimated and compared with the system maintenance costs for various maintenance intervals. It is observed that to attain high availability the maintenance interval of the components should be as low as possible which increases the maintenance cost. From a design perspective, it is important to compare availability with cost because different organizations typically assign different levels of significance to cost versus availability.



## **Chapter 1. Introduction**

### **1.1 Background**

The development in computer and information technology has led to a trend of integrating various operation facilities into large-scale systems. The result of this integration has significantly enhanced the productivity and efficiency of these systems. On the other hand, the integration has also created strong functional dependency between the components of the system. Failure of any of these components of the system could disable the whole system and cause serious financial and safety losses.

Today maintenance has become increasingly large portion of the total operation cost as systems are equipped with very sophisticated and high technology components. Maintenance is the job performed to maintain such highly technological and sophisticated components and systems in their original operating condition to the maximum extent possible [22]. Effective planning of maintenance activities minimizes the cost of maintenance and product variability, while enhancing product availability and reliability. This ensures high quality goods and services with minimal defects. There are hardly any systems which are designed to operate without any kind of maintenance, and for the most part they operate in environments where access is very difficult. In such systems replacing a component or system is more economical than performing maintenance on it [18]. Identifying a cost effective maintenance program is a primary objective. The cost of maintenance is easily quantified by labor and hardware costs; however, the benefits of maintenance are not so obvious [24]. To express the trade-offs between maintenance costs and benefits, an appropriate maintenance policy and relevant system performance measures are needed. These are typically brought together in what is called a maintenance optimization model.

This is a mathematical model in which both costs and benefits of maintenance are quantified and an optimum balance between the two is obtained.

## **1.2 Maintenance Strategies: Corrective Maintenance and Preventive Maintenance**

For most systems there are two classes of maintenance, corrective and preventive. Corrective maintenance (CM) is performed in reaction to failure and comprises of activities that are required to restore a system to an operating level after a known or suspected failure has occurred. CM can include any or all of the following steps: localization, isolation, disassembly, interchange, reassembly, alignment, and checkout. No activity will be taken as planned or scheduled while the system is still functioning. In this case the cost of the activity increases when the unplanned system failures increases. CM generally reflects the philosophy “if it isn’t broken, don’t fix it” [5].

Preventive maintenance (PM) consists of scheduled activities performed to reduce the number of system failures, thus reducing unplanned system downtime. The objectives of PM program includes: minimizing the maintenance cost, minimizing the number of unexpected breakdowns in the system so that financial and safety losses can be restrained. It also increasing the productive life of all equipments and last but not the least it helps in promoting better safety and health of the work force [11].

PM can be further classified under condition-based and time-based policies [22]. Condition based PM is sometimes referred to as predictive maintenance estimate, through diagnostic tools and measurements, when a part is near failure and should be replaced. Advancement in modern sensors and data processing technologies promote the development of such strategies. Time-based PM is effective mainly for deteriorating systems with increasing failure rates and is performed according to the age of the system regardless of its condition. Most of the research work in maintenance policies is under this category. By and large condition-based and time-based PM policies are applied jointly.

There is another type of maintenance known as Opportunistic maintenance (OM) which is a special type of PM and is performed on a unit when some other unit in the system is undergoing PM. It is one of the principal ways to maintain a continuous system where periodic shutdown is impractical.

### **1.3 Maintenance Dependency: Stochastic and Economic**

From the system modeling point of view, a system can be considered either as a single-unit system or a multi-unit system. Most systems addressed in the field of maintenance research have been single unit systems. In a single-unit model, the entire system is viewed as one component. Its failure distribution, failure process, maintenance activities and effects are well defined. Assuming a single distribution for the system failure process is not realistic or practical and does not help much in maintenance program development.

In recent days this conception has been relaxed and system with multi-units is being considered as most real world systems are complex in nature, and may consist of hundreds of different components. In multi-unit systems the entire system can be broken into subsystems or components and for whom the failure distributions are more traceable [15]. The maintenance activities and associated costs and effects for such systems are well defined. A multi-unit system is a group of several individual single-unit systems.

The decision to model a system as a single unit system or multi-unit system depends on the type of dependency between the units. If the dependency between the units is weak, single unit models can be applied. But if the dependency between the units is strong single unit models cannot be applied because this assumption might not provide good results in terms of overall system performance measure.

There are essentially two types of dependency between the components of a system, stochastic and economic [23]. The transition probability of one component is dependent on other component in a multi-unit system. This is stochastic dependency, and in such case the failure of

one component may increase the failure probability of another component. Stochastic dependency can also be caused due to maintenance activities like dusting, cleaning, or oil change. Economic dependency is the other type of dependency which suggests that it is more economical to replace several components together rather than replacing them separately. This is also referred to as opportunistic maintenance which is the base of this research. When opportunistic maintenance is performed only a minimal variable cost is added to replace other components but a lot of other fixed cost is saved.

Examples of the system where economic dependency exists are: Aircrafts, power generators, chemical plants, mass-production manufacturing lines. Most of these systems are continuous operation systems. In these types of systems, maintenance activities can only be performed when the entire system is shut down. Shutting down the entire system for single replacement or maintenance activities is much more expensive than replacing several components together. These systems should be modeled as multi-unit systems.

#### **1.4 Steady State Behavior versus Transient State Behavior**

Studies in failure and replacement models of individual units in past have mostly emphasized on steady state or equilibrium behavior in preference to transient behavior. As compared to steady state analysis which looks at the system failure and replacement in the long run, transient analysis studies the system failure and replacement behavior in the finite planning horizon i.e. during its useful life. Every practical system in this world has a transient state, even if it is very short. Modeling opportunistic maintenance policy of a multi unit system under transient state is the base of this research. Stochastic models for steady state and transient state in this research are developed based on the renewal theory concept.

## 1.5 Availability Analysis

Fault tolerance and flexibility are the prime attributes of any system. The degree of fault tolerance of a system is characterized by dependability measure such as reliability and availability [14]. Given an interval  $[0, t]$ , the reliability of the system is the probability that the system never reaches a failed state during that interval. Availability is defined as the probability that the system is in operational state at given time  $t$  i.e. not failed or has been restored after failure [10]. It is a performance criterion for repairable systems which accounts for both reliability and maintainability. Availability can be classified in the following ways:

1. Interval availability is the portion of time during a time period in which the system is available for use. Interval availability is represented by the mean value of the instantaneous availability over a period of time [7].
2. Instantaneous availability, also known as point availability is defined as the probability that the system is operational at any time  $t$ . Instantaneous availability is always greater than or equal to the reliability of the system [7].
3. Steady state availability of the system is the limit of the instantaneous availability function as time approaches infinity or a large value. Steady state availability is a stabilizing point where the system availability reaches a constant value.

This research focuses on deriving and measuring instantaneous availability of the units in the system. Renewal theory approach and transient analysis is used for this purpose.

## 1.6 Research Objectives

This thesis defines a multi-unit system and describes an appropriate opportunistic maintenance policy for it under transient state. While different maintenance policies of multi-unit systems have been discussed in the literature, past research has mostly addressed systems subject to steady state behaviors. Opportunistic maintenance policies for multi-unit systems under transient state have not been discussed much in the literature. The main feature of the plan is to

study the system for its useful life and not till infinity which is the steady state notion. A probabilistic mathematical model based on renewal theory concept is developed according to the proposed maintenance policy for transient state. The effectiveness of the policy and model is studied through comparison with preventive maintenance policy.

A further objective of this research is to develop an appropriate performance measure of the system. Instantaneous availability, a common measure of system effectiveness, is often called as operational readiness [24]. It is a function of operating time and down time. The availability expression must capture the unique nature of a system of components under transient behavior. This is the performance measure developed for the system under study in this thesis. Ultimately, the goal of the modeling endeavor is to optimize certain system parameters such as age replacement times.

The organization of the material in this thesis is as follows. Chapter 2 describes the literature relevant to maintenance planning, transient state behavior, recent modeling work in maintenance and availability and renewal theory applications. Chapter 3 gives a description of the problem addressed in this thesis. Chapter 4 provides the mathematical formulation and the modeling approach for the optimal maintenance interval of an individual unit under steady and transient behavior. It also provides the formulation for the instantaneous availability model. Numerical results are discussed in chapter 5 followed by the conclusion and a summary of the future research in chapter 6.

## **Chapter 2. Literature Review**

The basis of this research, maintenance policies has steadily grown for over three decades. A maintenance optimization model maximizes system performance by balancing the cost and benefits of a sound maintenance plan. Maintenance modeling has succeeded in theoretical as well as applied models, and its success is obvious by the growing number of models being developed and discussed in the literature.

The purpose of this literature review is to give an overview of modeling systems with maintenance activities and their impact and recent renewal theory applications to maintenance planning. This chapter gives a brief review of the literature available for the procedures developed for solving problems related to maintenance decisions. The following sections are organized as: 1. Maintenance policies, 2. Renewal theory applications, 3. Transient behavior applications and 4. Availability analysis.

### **2.1 Maintenance Policies**

#### **2.1.1 Preventive Maintenance Models**

The study of preventive maintenance as a research discipline began in the early sixties. Barlow, Proschan, Jorgenson, Rander and Hanter [1, 2] have contributed a lot in the early developments of maintenance models. As the importance of maintenance became more apparent so the scope and depth of this field which is also supported by the growth in the development of preventive maintenance models.

Mc Call [12] surveyed preventive maintenance policies. Wang [31] surveyed summaries and compares the various existing maintenance policies for both single and multi-unit systems.

Different policies such as age dependent preventive maintenance policy, the periodic preventive maintenance policy, the failure limit policy, the sequential preventive maintenance policy, etc are studied for single unit systems. All the policies studied by Wang are reviewed under different degrees of maintenance that is minimal, imperfect and perfect. He also reviews the policies of multi unit systems such as group replacement policy and opportunistic maintenance policy. Every policy has its own advantages and disadvantages and depending on the specific characterization under consideration, the optimal policy is chosen.

Valdez-Flores and Feldman [30] has classified maintenance models into four basic categories. Inspection models and shock models constitute condition based models, and minimal repair model and replacement models constitute time based model. Condition based maintenance is a function of the state of the system where the state usually cannot be determined without inspection. Time based models are a function of operation time of a system or age of a system.

Vermeulen [30] models the influence of preventive maintenance on the reliability performance of a protection system with the assumption that all the transition times are exponentially distributed random variables and the repair times are neglected. This is done to account for the state space reduction. A reward structure is added to evaluate and compare the different situations presented by the vector of the state probabilities, which is the solution to the continuous time Markov chain.

A Weibull analysis was used to investigate the failure patterns of radiators in the cooling system of different bus types in a large public transportation company by Chan, Mui and Woo [3]. In this analysis a renewal function  $W(t)$  of the Weibull distribution is computed. It is concluded that an overhaul of the radiators once in several years when the bus undergoes a major overhaul is more cost  $C(t)$  effective than preventive maintenance. The renewal function was computed and cost in terms of the renewal function was calculated. The expression for the renewal function and cost is as shown below.



$$W(t) = \sum_{K=1}^{\infty} \frac{(-1)^{k-1} A_K \left(\frac{t}{\alpha}\right)^{K\beta}}{\Gamma(K\beta + 1)} \quad (2.1)$$

$$C(t) = \frac{[A + W(t)(B_1 + B_2)]}{t} \quad (2.2)$$

Here  $\alpha$  and  $\beta$  are the Weibull shape and scale parameters,  $A$ ,  $B_1$  and  $B_2$  are the cost parameters and  $t$  is the width of the preventive maintenance interval.

### 2.1.2 Opportunistic Maintenance Models

Opportunistic maintenance concept originates from the fact that there can be a possibility of dependence between various components of a multi-unit system. Several researchers have proposed various models for opportunistic maintenance policy.

Opportunistic maintenance policy presented by Zheng and Fard [33] implements joint replacement for maintenance of multi-unit systems. In this paper hazard rate tolerance  $u$  and hazard rate limit  $L$  form a hazard rate interval  $(L-u, L)$ . This interval provided a standard for preventive replacement wherein more than one unit could be preventively replaced at the same time i.e. opportunistic maintenance. The policy deals with multi unit systems with no replacement downtime. An approximate mathematical model using renewal theory approach is developed to measure the system cost rate. It is assumed that the planning horizon is infinite and units followed exponential distribution.

A methodology for preventive maintenance analysis under transient response was discussed by Okogbaa and Xia [16]. The approach consists of two major components, in the first component, the analytical models based on renewal theory incorporated maintenance cost in formulating maintenance decision problems and the second component used numerical methods for solving the resulting differential and integral equations. The methodology includes two phases. The first phases is the study of failure-repair process of a multi-unit system with just one

increasing failure component and rest all constant failure component under transient analysis. In the second phase the transient analysis is extended to more than one increasing failure rate component. Runge-Kutta method is used to solve the differential equations which were generated from integral equations.

Stochastic dependency problem has been studied by many researchers in addition to the economic dependency problem. Due to the difficulty in obtaining the joint probability distribution among components, most of the researchers in this area have to resort to finite-state Markov or Semi- Markov models like by Bhat and Howard.

## **2.2 Renewal Theory Applications**

Renewal theory is a well known and appropriate method to model a stochastic failure process. It is a widely used method in maintenance planning and other applications as well. Renewal process is a counting process in which the times between successive events are independent and identically distributed [19]. The system is said to renew itself at random points of time. An advantage of modeling system failure process as a renewal process is that the system failure causes and the underlying probability structure associated the distributions are tracked and identified. Some of the applications of the renewal theory have been discussed in the following papers.

Barlow and Hunter [1] developed the Age replacement model for single unit system based on the renewal theory assumption. It assumed that whenever a maintenance activity is performed, the system gets restored to an as-good-as new condition. Such an assumption limited its application to single unit system. The maintenance policy was to replace the system when it fails or when it reaches an age  $T$ , whichever occurs first. The decision problem was then to find the optimal preventive replacement age  $T$ . Expected total maintenance cost over the system planning horizon was calculated assuming the failure cost and the preventive maintenance cost. The resulting transcendental equation was solved and the optimal age  $T$  was the obtained.

In renewal theory, landmark work was done by Cox [4]. He developed an availability model that optimizes age replacement time over a finite operating horizon. Murdock [13] included an extensive discussion on the history of maintenance planning and systems that benefit from a preventive maintenance policy. He explains the implementation of Laplace transform in modeling and optimization process.

A modeling procedure to optimize component safety inspection over finite time horizon was discussed by Wang and Christer [32]. The model established was based on the earlier work which assumed infinite time horizon and used the concept of delay time and asymptotic results from the theory of renewal and renewal reward process. Closed form and asymptotic (infinite time horizon) form expressions for the renewal function were derived. Renewal reward process concept was used to formulate the cost function. The asymptotic form of expression for the total cost occurring in a given time interval was given by the following equation:

$$\frac{C(T)}{T} = \frac{\mu_y}{\mu_x} + \frac{\frac{\sigma_x^2 + \mu_x^2}{2\mu_x^2} \mu_y - E(Y_{N(T)+1}) + E(\varepsilon(T))}{T} \quad (2.3)$$

Where  $\mu_x$  and  $\sigma_x$  are the mean and variance of the inter arrival times  $X$  between renewals and  $\mu_y$  is the mean of the cost occurring within a renewal interval.  $\varepsilon(T)$  is the accumulated inspection cost. Closed form of expression for the total cost occurring in a given time interval was given by the following expression:

$$C(T) = M(T) + \int_0^T C(T - \nu) dQ(\nu) \quad (2.4)$$

Here  $\nu$  is the age at which the first renewal occurs. The results from the above cost expressions and the delay time concept are used to establish the finite time horizon inspection model. Merits of the closed form (exact) and asymptotic formulations are discussed. The results of the inspection model are discussed in the next section.

Rupe and Kuo [20] modeled a flexible manufacturing system (FMS) using renewal theory. The effectiveness of a FMS was evaluated through stochastic modeling of failure and repair of the system components. Here as the repair time was not exponentially distributed, the system was renewed only at the instants when a repair is first complete. An example of FMS was discussed in which a relative failure rate for each of the replaceable parts and for the system for each possible combination of failed machines was given. First the probability distributions were calculated which were used at many different phases of the model development, then the distributions for the change in the number of failed machines that is machine failure distribution was found out. By applying the results formed the Semi-Markov model was formed. The failure and success probabilities found were combined to yield the probabilities of having each possible number of down machines and finally the performance measure was calculated.

### **2.3 Transient Behavior**

The concept of modeling maintenance policies over finite time horizon or studying the transient behavior of a system is fairly new and is difficult to model. There is very scanty literature available on this topic. Some researchers in recent times have modeled there research using different methodology assuming non steady state behavior.

As discussed in the above section Wang and Christer [32] modeled a procedure to optimize component safety interval over a finite time horizon. Here the concept of delay time and asymptotic results from the theory of renewal and renewal reward process are used to model a single dominant failure mode which has considerable safety and risk consequences assumed measurable either in cost terms or in terms of the probability of failures over a time horizon. An asymptotic formulation of the objective function is used to optimize the inspection process over a finite time zone and the solutions are checked and refined using simulation. The formulation which is based on the renewal theory concept is already discussed in the previous section. The

expected cost per unit time over  $T$  versus different uniform inspection intervals is evaluated and the results generated are as shown in figure 2.1.

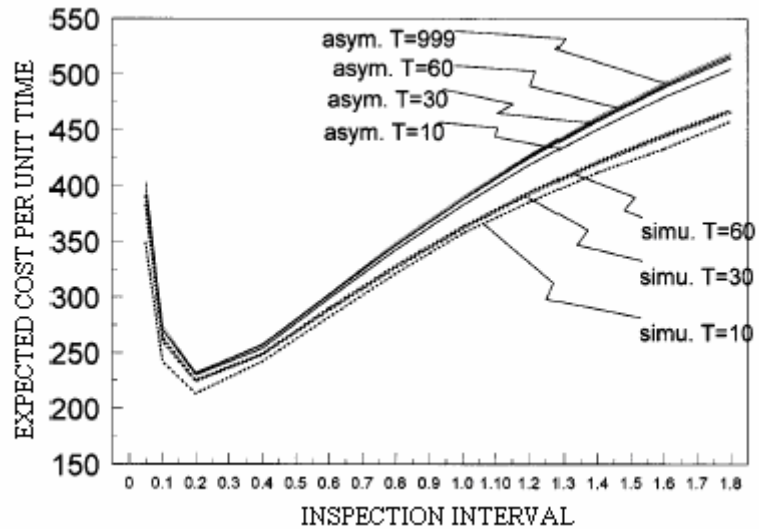

**Figure 2.1:** Expected Cost per Unit Time over Finite Time Horizons versus Inspection Intervals

Analysis of the transient behavior of the times-between-failure (TBF) is discussed by Keats and Chambal [9]. The focus of interest in this paper was to identify the time when the TBF's reflect the exponential property sufficiently to assume the use of the exponential in the practical applications. Reliability simulation (reliability block diagram) is used to demonstrate the transient behavior and in identifying the point at which the exponential distribution is appropriate for selected systems. This study is a general analysis on a predetermined set of reliability block diagrams with randomly selects failure and repair distribution. The configuration of a ten component system used here is as shown in figure 2.2. Simulation of these systems is performed using reliability block diagram simulation software developed by United States Air Force.

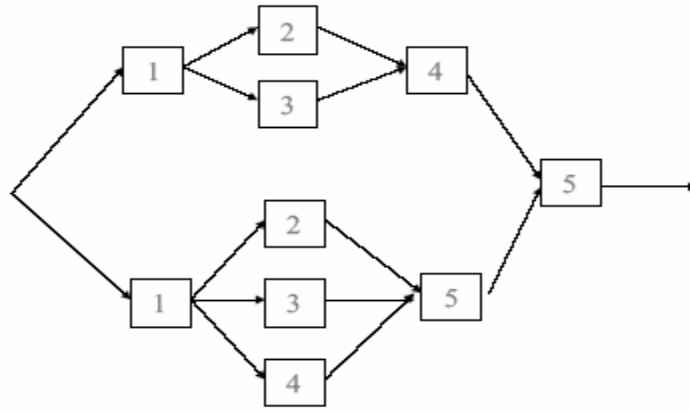

**Figure 2.2:** Ten Component System

It is observed that when a ten component system is manipulated and the transitional behavior is observed, the TBF distribution converges to the exponential with an appropriate mean within 30 system failures. Similarly five and fifteen component systems are studied.

Expressions for expected downtime and expected costs are derived and compared between steady state and transient conditions by Vaidyanathan, Selvamuthu and Trivedi [28]. Optimal value of the inspection interval which minimizes expected downtime and cost for an assumed set of parameter values are obtained. This system is assumed to experience Poisson failure i.e. constant failure rate and therefore an analytical model of a software system employing inspection based preventive maintenance through Markov regenerative process with a subordinated semi-Markov reward process is presented. The state transition diagram for preventive maintenance is as shown in figure 2.3. The time domain probabilities were computed by numerically inverting equation 2.5. The transient availability was computed by equation 2.6. It is observed from the plot of deterministic interval that transient availability ripples for some time before settling down.

$$V^*(s) = [I - sK^*(s)]^{-1} E^*(s) \quad (2.5)$$

$$A(t) = \sum_0^K \pi_{D_j}(t) \quad (2.6)$$

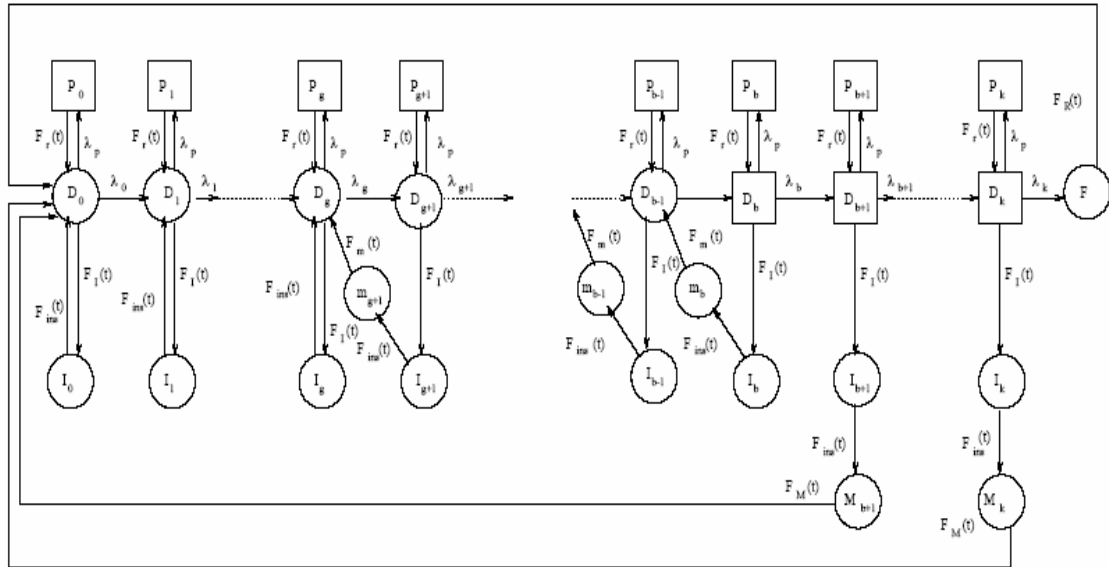

**Figure 2.3:** State Transition Diagram for Preventive Maintenance

## 2.4 Availability

Availability is defined as the probability that a system is operational at any time  $t$ . As mentioned earlier there are different ways in which availability can be classified. Extensive literature is available on solutions and applications of steady state availability. Due to the advancement in technology and competition a product or a component may be in use for just a couple of years. That is the reason why instantaneous and interval are more important matrices than steady state availability. In recent times there have been few researchers who have contributed their work towards finding instantaneous and interval availability.

Kuo and Rahman discussed the availability modeling of a flexible manufacturing system application with a suitable Markov model. State probabilities for availability were obtained by steady state equations derived from the Markov model with exponentially distributed sojourn times. A performance measure was also obtained. There were several weaknesses in the model such as, it was limited to exponentially distributed service times, there was no spare parts arrival

modeling, the technicians were dedicated to single parts and if there was failure under some conditions the system was assumed to shut down.

Hui and Wang [6] discussed the reliability and performability analysis of a repairable and degradable automatic train protection (ATP) system. In this paper ATP systems reliability, system availability, mean time to systems first fault and systems performability measures are obtained using Markov renewal processes and probability theory. It is assumed that each unit's lifetimes of ATP system obeys exponential distribution and the distribution of the repair time is arbitrary distribution. First the reliability of all the subsystems are calculated when failure rate is known, and then the transient and steady state availability are calculated using the reliability of the whole system and subsystems. The system is composed of an extended Markov renewal process. With the help of this method, equations for the probabilities of system in different states are derived. Laplace transform of the equations is done and availability of transient and steady states is calculated.

A stair step approximation to the instantaneous availability and interval availability for systems with time varying failure rate has been presented by Sun and Han [26]. It has been shown that the mean time to failure (MTTF) and mean time to repair (MTTR) which is used to calculate steady state availability i.e. equation is a neat expression for availability only when failure rate is constant.

$$A = \frac{MTTF}{MTTF + MTTR} \quad (2.7)$$

In case of time varying failure are instantaneous and interval availability are calculated using stair-step approximation. This approximation is based on the observation that the time varying property for failure rate is exhibited at a large time scale such as a year or a month. Within one day or one week the variation of failure rate is insignificant. Instantaneous and interval availability of a system with Weibull failure rate and constant repair rate are calculated and the results are compared with steady state availability.



Based on the similar concept Sun and Han [27] proposed a truncated bath-tub methodology to model the failure rate of a product (component) with perfect burn-in. Closed form of MTTF for exponential and Weibull distributions were derived and results for steady state and instantaneous availability were compared. There were some important observations made like increasing the MTTF did not always increase the average and instantaneous availability. It was also observed that the average and instantaneous availability could be improved without changing the MTTF.

Jacobson and Arora [8] presented a non-exponential approach to availability modeling. A general approach for calculating instantaneous availability was presented which was based on renewal theory concept. Availability was calculated based on the following equation:

$$A(t) = R(t) + \int_0^t R(t-s)m(s)ds \quad (2.8)$$

Where  $R(t)$  is the reliability function and  $m(s)$  is the renewal rate.

Regression analysis [19] is used to calculate the function. Simpson's composite trapezoidal algorithm is used for numerical integration as it is a closed form of integral. There are two case studies presented, first is a validation study based on exponential distribution assumption to obtain analytical results of availability. First case study is compared with second that is based on the assumption that uptimes follow Weibull distribution and downtimes follow lognormal distribution.

### **Chapter 3. Problem Statement**

Any real world system consists of many working components with different failure modes and maintenance cost structure. Time to time replacement of the failed components is absolutely necessary to reduce system failures and thus lowering maintenance cost. However if replacements are done too frequently, the cost becomes very high. An optimal replacement interval should be planned for each unit in a system to optimize cost.

In this research the issue of time based opportunistic maintenance planning for multi-unit systems with economic dependency for finite time horizon is discussed. By and large stochastic and or economic dependency between the components of a system exists. The term economic dependency between components suggests that it is more economical to replace two or more components together at the same time. Whenever a maintenance operation is performed on any system, a one time fixed cost is incurred, like system shut down cost, which is very significant as compared to the other costs like replacing a component. For example, car maintenance involves a high labor cost and the cost of driving the car to the maintenance facility could be considered as a fixed cost. However when a maintenance is being done, replacing one or more additional components may involve only marginal cost as compared to the high fixed cost. If the cost of replacing these additional components is not too high, then it is more economical to replace them together at the same time of maintenance than replacing them separately. However, it is very difficult to evaluate and explore such an opportunity because the lives of the units in the system are probabilistically distributed.

Let us consider an example of simple system with two components  $A$  and  $B$  with mean probabilistic life equal to 4 and 6 months. Cost of replacing  $A$  due to PM is \$200 and due to OM is \$150. Cost of replacing  $B$  is due to PM is \$300 and due to OM is \$200 respectively.  $A$  fixed cost of \$1000 is incurred while replacing  $A$  or  $B$  or both. Now suppose  $A$  fails at 3 months. So a cost of \$1200 is incurred while replacing  $A$ . If at the same  $B$  is also replaced due to OM, a total cost of \$1400 will be incurred. If  $A$  and  $B$  are not replaced together i.e. they are replaced at different times then it would cost a total of \$2500. This might seem reasonable because with just an additional cost of \$200 new components of  $A$  and  $B$  can be used, but it is also questionable that can replacing them together be more cost effective because life of  $B$  here is not deterministic but probabilistic.  $B$  might not fail till 10 months. Similar decision problems can arise at any moment throughout the system life under different scenarios.

The maintenance decision process in general includes the analysis of maintenance cost, number of units in the system, failure distribution of each unit, and current state of the system. The decision process becomes even more difficult when number of units in the system increase and thus increases the possible states of the system. The primary decision of maintenance planning should include what components should be replaced under which circumstances and at what time instants. For this decision it is very important to develop effective approaches and models of opportunistic maintenance program.

The decision is to find the times for preventive and opportunistic maintenance such that the expected system's maintenance cost per unit time is minimized. Failure repair process is first discussed. The optimal times for preventive maintenance for finite time horizons are then calculated using renewal theory approach. A simulation model for PM and an OM policy is presented. Instantaneous availability for finite time horizon is also measured using renewal theory approach. Modeling methodology is discussed in the next chapter.

## **Chapter 4. Modeling Methodology**

### **4.1 System Description and Assumptions**

#### **4.1.1 System Description**

The system studied in this research is a four component multi-unit system where the term “unit” could be a component, a set of components, or even a subsystem. Although the system studied is a four component system, it can be generalized to an  $N$  component multi-unit system as the components in the system are economically dependant but stochastically independent. The system studied here is for a finite time horizon i.e. the useful life of the system.

#### **4.1.2 Assumptions**

This system comprises of units, which are economically dependant buy may or may not be stochastically dependant.

1. The system under consideration is a four component multi-unit system which can be generalized for an  $N$  component multi-unit system.
2. The planning horizon for the maintenance policy studied is finite i.e. till its useful life.
3. Components of the system are economically dependant but stochastically independent.
4. Components exhibit increasing failure rate i.e. aging effect.
5. Components follow Weibull failure distribution with shape and scale parameters.
6. Repairs or maintenance times are assumed to follow lognormal distribution.
7. Failure of or maintenance on any component disables the system.

8. Maintenance either corrective or preventive implies replacing one or more components with identical new ones (as good as new condition).
9. Each time a component is replaced, the system incurs a high fixed cost.
10. Corrective maintenance cost is much higher as compared to preventive maintenance cost.
11. Opportunistic maintenance is performed only during preventive maintenance.
12. Opportunistic replacement interval is a fraction of preventive replacement interval.

#### 4.1.3 Notations

$f(t)$  probability density function of lifetime distribution for the individual unit

$F(t)$  cumulative distribution function corresponding to  $f(t)$

$\alpha$  shape parameter for the Weibull distribution

$\beta$  scale parameter for the Weibull distribution

$\sigma$  standard deviation for the lognormal distribution

$\mu$  mean for the lognormal deviation

$T$  finite planning horizon

$t_A$  optimal preventive replacement interval

$t_P$  opportunistic replacement interval

$C_F$  fixed replacement cost

$C_O$  opportunistic replacement cost

$C_C$  corrective replacement cost

$C_P$  preventive replacement cost

$E[L]$  expected length of the replacement cycle

$E[C]$  expected cost of the replacement cycle

$C(T, t_A)$  cost of maintenance of the unit in finite planning horizon  $T$ , employing PM policy  $t_A$

$t_A^*$  optimal age replacement interval of the unit

## 4.2 Failure and Repair Process

By and large most of the literature addresses the systems where the repairs and/or maintenance times are assumed negligible. In this research it is assumed that failures times follow Weibull distribution and maintenance times and/or repairs follow lognormal distribution. Figure 4.1 shows a failure and repair behavior of a system where  $f$  denotes the failure time,  $r$  denotes the repair or maintenance time and  $v$  denotes the time for failure-repair process.

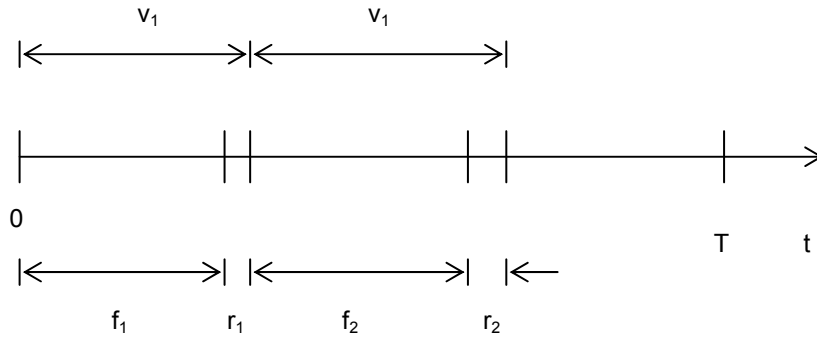

**Figure 4.1:** Failure-Repair Process

The probability density function  $f(t)$  of Weibull distribution is expressed as follows:

$$f(t) = \frac{\alpha}{\beta} \left( \frac{t}{\beta} \right)^{\alpha-1} \exp \left[ - \left( \frac{t}{\beta} \right)^\alpha \right], 0 \leq t \leq \infty \quad (4.1)$$

Where  $\alpha$  is the shape and  $\beta$  is the scale parameters of the times-to-failures.

The probability density function  $f(t)$  of lognormal distribution is expressed as follows:

$$f(t) = \frac{1}{t \cdot \sigma \sqrt{2\pi}} \exp \left[ - \frac{1}{2} \left( \frac{\ln(t) - \mu}{\sigma} \right)^2 \right], 0 \leq t \leq \infty \quad (4.2)$$

Where  $\sigma$  is the standard deviation and  $\mu$  is the mean for the times-to-repair.

It is required to identify the distribution  $f(v)$  of failure and repair together i.e. Weibull + lognormal. This distribution cannot be obtained analytically. We use simulation to estimate the resulting distribution of failure and repair.

Random times for Weibull and lognormal distributions are first generated using MATLAB. These are the random failure and repair times of the system. These random times are then added. This is the time at which the failure and repair cycle is completed. These numbers are then sorted in the ascending order and the CDF is estimated. Parameters of this new distribution are estimated. KS test is used to determine the goodness of fit.

#### **4.3 Steady State and Transient State Age Replacement Policy**

This chapter focuses on the steady state and transient state analysis of failure and replacement behavior of a single unit. Steady state analysis looks at the system failure and replacement behavior in the long run, whereas transient state analysis studies the system failure and replacement behavior in a finite planning horizon. A stochastic model based on renewal process concept is developed in order to study the steady state and transient state behavior of the unit. Optimal replacement intervals are calculated by solving the integral equation.

This section is organized as follows:

1. Age replacement policy for a single unit under steady state
2. Age replacement policy for a single unit under transient state

### 4.3.1 Steady State Age Replacement Policy

Single unit preventive maintenance problem for steady state is also known as traditional preventive maintenance policy and was studied first by Barlow and Proschan [1] using renewal process theory. This model has been frequently used as the basis to develop complicated maintenance models due to its mathematical clarity and for being statistically sound.

The system studied here is for a single unit. Maintenance implies replacing the unit with an identical new one. A unit is replaced when it fails or when it reaches its preventive replacement age (active replacement), whichever occurs first. When the unit is replaced due to failure a cost  $C_C$  is incurred. When the unit is replaced due to its preventive replacement age, a cost  $C_P$  is incurred. Generally  $C_C \gg C_P$ .

The unit is replaced with a new identical one, so the replacement is a renewal process. The cost associated with the failure of the unit and resulting age replacement policy under steady state is modeled using renewal theory concept. The probability of the unit being replaced due to failure is  $F(t)$  and the probability of the unit being replaced due to preventive replacement is  $1 - F(t)$ . According to the maintenance policy, the expected life of the unit during a maintenance cycle is expressed as:

$$E[L] = \int_0^{t_A} t f(t) dt + T \int_{t_A}^{\infty} f(t) dt = \int_0^{t_A} (1 - F(t)) dt \quad (4.1)$$

Where  $t_A$  is the optimal preventive replacement interval

Expected maintenance cost during a cycle is expressed as:

$$E[C] = C_C \int_0^{t_A} f(t) dt + C_P \int_{t_A}^{\infty} f(t) dt \quad (4.2)$$

$$E(C) = C_C F(t_A) + C_P (1 - F(t_A)) \quad (4.3)$$



The expected average cost per unit time is

$$C(T) = \frac{E(C)}{E(L)} \quad (4.4)$$

$$C(T) = \frac{C_C F(t_A) + C_P (1 - F(t_A))}{\int_0^{t_A} (1 - F(t)) dt} \quad (4.5)$$

The objective is to minimize this expected average cost per unit time  $C(T)$ . The age  $t_A$  which minimizes the average expected cost  $C(T)$  is the optimal preventive replacement age  $t_A^*$  for the unit.

#### 4.3.2 Transient State Age Replacement Policy

Preventive maintenance problem under transient state is much more difficult to model as compared to that under steady state and not much research has been done under this assumption.

Under this assumption a unit is repaired or replaced when it fails or when it reaches its preventive replacement interval, whichever occurs first. Similar to the steady state analysis, here the unit is replaced with a new and identical one. The replacement process is a renewal process. The cost associated with the failure of a unit and the resulting age replacement policy under transient response is modeled using renewal theory concept. . The probability of the unit being repaired or replaced due to failure is  $F(t)$  and the probability of the unit being repaired or replaced due to preventive replacement is  $1 - F(t)$ .

Let  $v$  is the time when the repair is complete after failure,  $t_A$  is the PM interval, and  $T$  is the finite planning horizon. There can be two cases, when  $t$  is less than  $T$  ( $t_A < T$ ) and when  $T$  is greater than  $t$  ( $t_A > T$ ).

### 4.3.2.1 Case 1

In this case PM interval is less than the finite planning horizon, so there can be some PM's in this period  $(0, T)$ .

The cost associated is as follows:

1. If component fails before PM time  $t_A$  ( $v < t_A$ )

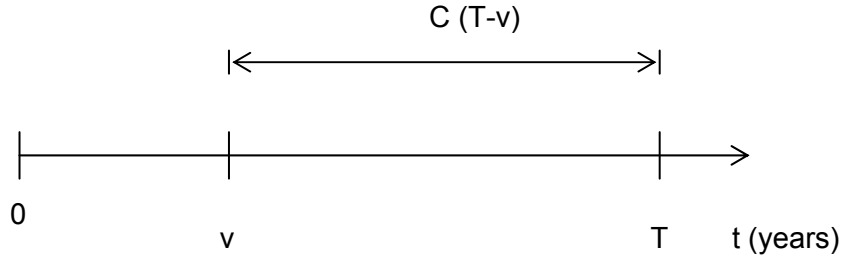

**Figure 4.2:** Replacement Due to Failure ( $v < t_A$ )

The planning horizon is reduced to  $(T-v)$  and the cost due to CM is incurred i.e.  $C(T-v)$

2. If component is operational till  $t_A$ , and is replaced due to PM at  $t_A$ .

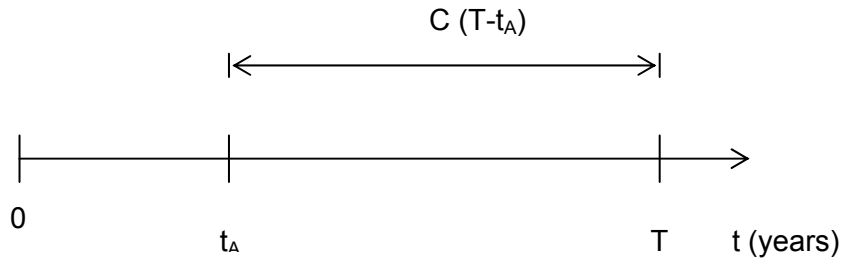

**Figure 4.3:** Replacement Due to PM ( $t_A < v$ )

The planning horizon is reduced to  $(T-t_A)$  and the cost due to PM is incurred i.e.  $C(T-t_A)$

The total cost incurred in these two cases is:

$$C(T, t_A) = \int_0^{t_A} [C_c + C(T-v)] f v dv + [C_p + C(T-t_A)] (1 - F(t_A)), 0 < t_A < T \quad (4.6)$$

$$C(T, t_A) = \int_0^{t_A} \{ [C_c - C_p - C(T-t_A)] + C(T-v) \} f v dv + [C_p + C(T-t_A)], 0 < t_A < T \quad (4.7)$$

#### 4.3.2.1 Case 2

In this case PM interval  $t$  is greater than planning horizon  $T$ .

In this case component is only replaced due to failure i.e. at  $v$  and the planning horizon reduces to  $(T-v)$ .

The total cost incurred in this case is:

$$C(T, t_A) = \int_0^T (C_c + C(T-v)) f v d v, t_A \geq T > 0 \quad (4.8)$$

Combining 1 and 2,

$$C(T, t_A) = \int_0^{t_A} \{ [C_c - C_p - C(T-t_A)] + C(T-v) \} f v d v + [C_p + C(T-t_A)], 0 < t_A < T$$

$$\int_0^T (C_c + C(T-v)) f v d v, t_A \geq T > 0 \quad (4.9)$$

The objective is to minimize this expected average cost per unit time  $C(T, t_A)$ . The age  $t_A$  which minimizes the average expected cost  $C(T, t_A)$  is the optimal preventive replacement age  $t_A^*$  for the unit.

Although the solution to equation exists, solving this recursive integral equation in the closed form is very difficult and almost impossible. Composite trapezoidal rule is therefore used to compute the expected average cost per unit time. By comparing all the cost values for different time units, we obtain the optimal age replacement interval that has the minimum cost value.

#### 4.4 Opportunistic Maintenance Policy

The economic dependency between the components is established by introducing a fixed maintenance cost  $C_F$  and opportunistic maintenance cost  $C_O$ . The fixed maintenance cost is a one time cost and can be such as the cost of closing production line, disassembling machine, cost of

mobilizing repair crew, etc. Fixed cost is always incurred when there is a maintenance activity in the system. Opportunistic maintenance cost is the cost incurred when a component is replaced due to opportunistic maintenance. Opportunistic maintenance cost is only incurred when there is opportunistic maintenance. If some other components are also replaced during this maintenance activity, we could save on the fixed maintenance cost  $C_F$  for these components and only a marginal opportunistic replacement cost will be incurred which is very low as compared to the fixed replacement cost.

Let us assume that  $C_C$  is the cost of corrective maintenance,  $C_P$  is the cost of preventive maintenance and  $C_O$  is the marginal cost of opportunistic maintenance of the component. If the component fails a cost of  $C_C+C_F$  will be incurred. If the component is replaced due to preventive maintenance the cost of  $C_P+C_F$  will be incurred. However if the component is replaced when some other component is replaced due to preventive maintenance, then only an additional cost of cost  $C_O$  will be incurred for that particular component and the fixed cost  $C_F$  will be saved. This is known as opportunistic maintenance.

Simulation models for preventive maintenance and opportunistic maintenance are presented which are used to compare the two models.

#### 4.4.1 Preventive Maintenance Simulation Model

1. STEP 0            Set a finite planning horizon  $T$ .
2. STEP 1            Let the total number of units in the system be  $N$ .
3. STEP 2            Assume cost parameters

Cost of corrective maintenance =  $C_C$

Cost of preventive maintenance =  $C_P$

Fixed cost of replacement =  $C_F$

4. STEP 3           Generate random times from Weibull and lognormal distributions and estimate the resultant distribution parameters
5. STEP 4           Compute the optimal replacement interval  $t^*$  for the units using equation 4.9.
6. STEP 5           Using the parameters estimated in STEP 3, generate random failure intervals  $(x_1, x_2, x_3, \dots, x_N)$ .
7. STEP 6           If  $x_1 \leq t^*$ , perform CM on the respective unit. Cost due to CM ( $C_C$ ) and cost fixed cost ( $C_F$ ) will be incurred.  
  
If  $t^* < x_1$ , perform PM on the respective unit. Cost due to PM ( $C_P$ ) and fixed cost ( $C_F$ ) will be incurred.
8. STEP 7           Repeat procedure for all the units in the system until the finite planning horizon  $T$ .
9. STEP 8           Compute the total cost incurred by the system due to maintenance procedures in the planning horizon  $T$ .

$$\sum C_{OM} = C_C + C_P + C_F$$

#### 4.4.2 Opportunistic Maintenance Simulation Model

1. STEP 0           Set a finite planning horizon  $T$ .
2. STEP 1           Let the total number of units in the system be  $N$ .
3. STEP 2           Assume cost parameters  
  
Cost of corrective maintenance =  $C_C$   
  
Cost of preventive maintenance =  $C_P$

Cost of opportunistic maintenance =  $C_O$

Fixed cost of replacement =  $C_F$

4. STEP 3      Generate random times from Weibull and lognormal distributions and estimate the resultant distribution parameters
5. STEP 4      Compute the optimal replacement interval  $t^*$  for the units using equation 4.9.
6. STEP 5      Let opportunistic maintenance interval  $t^*_O$  be  $2/3 \times t^*$ .
7. STEP 6      Using the parameters estimated in STEP 3, generate random failure intervals  $(x_1, x_2, x_3, \dots, x_N)$ .
8. STEP 7      If  $x_1 \leq t^*$ , perform CM on the respective unit. Cost due to CM ( $C_C$ ) and cost fixed cost ( $C_F$ ) will be incurred.  
  
If  $t^* < x_1$ , perform PM on the respective unit. Cost due to PM ( $C_P$ ) and fixed cost ( $C_F$ ) will be incurred.
9. STEP 8      If PM is being performed on the system and there is another unit or units in the system that have passed there OM interval  $t^*_O$ , perform OM on the units. Cost due OM ( $C_O$ ) will be incurred.
10. STEP 9      Repeat procedure for all the units in the system until the finite planning horizon  $T$ .
11. STEP 10      Compute the total cost incurred by the system due to maintenance procedures in the planning horizon  $T$ .

$$\sum C_{OM} = C_C + C_P + C_O + C_F$$

#### 4.5 Availability Measure

Transient state availability is defined as the availability of the system in a finite time horizon i.e. during its useful life. Modeling transient state availability is much more complicated as compared to modeling steady state availability. As discussed previously a unit is functional when the repair is complete after failure. The failure and repair process is a renewal process.

Let  $v$  be the time when the last repair is completed and  $T$  is the finite planning horizon as shown in figure 4.2. After the first repair is completed the planning horizon reduces to  $(T-v)$ . The unit may be functional at time  $T$  in two cases:

Case 1: When the unit has not failed till time  $T$ .

In this case the availability of the system is just equal to the reliability of the system and is expressed as:  $R(t)$

Case 2: When the unit failed at time  $F$  and was repaired and functional at time  $v$ .

In this case the unit has not failed since the last repair was completed with probability:

$$\int_0^T R(T-v)dv, 0 \leq v < T \quad (4.10)$$

Combining case 1 and case 2 results in the expression for the instantaneous (transient) availability of the system and is expressed as:

$$A(T) = R(T) + \int_0^T R(T-v)dv, 0 \leq v < T \quad (4.11)$$

This is a closed form of integral which cannot be solved analytically. Trapezoidal rule is used to solve the above expression for instantaneous availability.

## Chapter 5. Results and Analysis

This chapter discusses the results of the preventive and opportunistic maintenance models for transient state of a four component system. All the four components of the system are assumed to follow the IFR (increasing failure rate) Weibull failure distribution with corresponding shape and scale parameters. The data source is a real life system i.e. a production line [16]. It consists of an Aluminum hot roll line for reducing aluminum ingots from about size of 10 inches to approximately a quarter inch typically used for consumer based aluminum products. It is known that about 30 components of the Hot Roll line are responsible for the line failure. Of the 30 components considered, four are assumed to be critical. The shape and scale parameters for these four components are as given in Table 5.1. For the purpose of this research we have assumed that repairs or downtimes follow the lognormal distribution. The system availability as a performance measure has been studied in this research to enhance and improve designs.

**Table 5.1** Lifetime Distribution Parameters of Four Components for the Aluminum Line

	Machine	Shape ( $\beta$ )	Scale ( $1/\alpha$ )
1	Soaking E WBF	4.26	0.41
2	112" MILL E COIL	3.225	0.48
3	112" MILL E TRIMMER	3.259	0.65
4	112" MILL E HORN	4.197	0.38

### 5.1 Failure Repair Process

For most systems maintenance does take time and hence maintenance times are typically not negligible. In this research we have considered maintenance or repair times to follow the



lognormal distribution. All the components of the system are assumed to follow the lognormal repair distribution with a known mean and standard deviation. It is important to determine the joint probability distribution for failure and repair i.e. Weibull + lognormal. To estimate the joint probability distribution, simulation is used as follows:

1. Random failure and repair times for the four components are first generated using MATLAB.
2. These random failure and repair times are then added and sorted in ascending order. This is the time when the failure and repair process is completed.
3. The CDF and the parameters of this new probability distribution are then estimated.

Table 5.2 shows the parameters of the four components for Weibull, lognormal and the resultant joint probability distribution.

**Table 5.2:** Failure, Repair and Resultant Distribution Parameters for the System

	Machine	Failure Distribution		Repair Distribution		Resultant Distribution	
		Shape ( $\beta$ )	Scale ( $1/\alpha$ )	Mean ( $\mu$ )	SD ( $\sigma^2$ )	Shape ( $\beta_R$ )	Scale ( $1/\alpha_R$ )
1	Soaking E WBF	4.26	0.41	0.353	1.26	1.002	0.331
2	112" MILL E COIL	3.225	0.48	0.353	1.26	0.901	0.26
3	112" MILL E TRIMMER	3.259	0.65	0.353	1.26	1.123	0.27
4	112" MILL E HORN	4.197	0.38	0.353	1.26	0.89	0.319

It is observed, based on the plots, that the resultant distribution appears to be the Weibull distribution with the given shape and scale parameters. This is to be expected, since the cycle times are short and thus are dominated by Weibull failure distribution. The role of the lognormal repair distribution, for the most part is insignificant in determining the cycle times [8] because of its assumed duration. K-S test is then used to verify that the resultant distribution is a Weibull distribution. The Weibull, lognormal and combined plots for the first component are shown in figure 5.1, 5.2, 5.3. The resultant parameters for the four components would be used throughout this research for modeling purposes. A KS test is performed to check the goodness of fit for the resultant distribution i.e. Weibull distribution.

### 5.1.1 Kolmogorov-Smirnov test

The Kolmogorov-Smirnov (KS) test is used to decide if a sample comes from a population with a specific distribution [25]. Here we perform a KS test to decide if the resultant distribution is a Weibull distribution or not. Null hypothesis is presented.

$H_0$ : The resultant distribution  $F(v)$  is a Weibull distribution

$H_1$ : The resultant distribution  $F(v)$  is not a Weibull distribution

Reject  $H_0$  if  $D > \text{Critical value}$

Reject  $H_1$  if  $D < \text{Critical value}$

If after a random sample of  $n$  values of  $v$  is observed,  $F(v)$  should be close to  $F_n(v)$  for null hypothesis to be true.  $F_n(v)$  is the empirical distribution function.

$F_n(v)$  = fraction of the sample less than or equal to  $v$

$$= \begin{cases} \frac{(i-1)}{n} & \text{if } v_{(i-1)} \leq v \leq v_{(i)} \quad i = 1, \dots, n \\ 1 & \text{if } v \geq v_{(n)} \end{cases} \quad (5.1)$$

The K-S statistic is based on the maximum distance between  $F(v)$  and  $F_n(v)$ .

$$D = \max_v |F(v) - F_n(v)| \quad (5.2)$$

The null hypothesis is rejected if  $D$  is too large.

To find the observed value of  $D$ , it is necessary to find,

$$D^+ = \max_{1 \leq i \leq n} \left[ \frac{i}{n} - F(v_i) \right] \quad (5.3)$$

$$D^- = \max_{1 \leq i \leq n} \left[ F(v_i) - \frac{i-1}{n} \right] \quad (5.4)$$

$$D = \max(D^+, D^-) \quad (5.5)$$

The values of the resultant data and pertinent values are as shown in table 5.3.

From the table it is observed that  $D^+ = 0.106$  and  $D^- = 0.062$

To find the critical value, we need to calculate

$$(D)\left(\sqrt{n} + 0.12 + \frac{0.11}{\sqrt{n}}\right) = (0.106)(7.20) = (0.763) \quad (5.6)$$

At  $\alpha=0.05$  i.e. 95% significance level, from the table [25] rejection region starts at 1.358.

Thus, we do not reject the null hypothesis, and hence the resultant distribution is a Weibull distribution.

**Table 5.3:** Data and Calculations for KS test

i	y(i)	F(yi)	i/n	(i - 1)/n	i/n - F(yi)	F(yi) - (i-1)/n
1	3.63	0.06	0.02	0.00	-0.04	0.06
2	4.10	0.08	0.04	0.02	-0.04	0.06
3	4.25	0.09	0.06	0.04	-0.03	0.05
4	4.65	0.10	0.08	0.06	-0.02	0.04
5	5.28	0.13	0.10	0.08	-0.03	0.05
6	5.39	0.14	0.12	0.10	-0.02	0.04
7	5.62	0.15	0.14	0.12	-0.01	0.03
8	5.93	0.17	0.16	0.14	-0.01	0.03
9	6.18	0.18	0.18	0.16	0.00	0.02
10	6.60	0.20	0.20	0.18	0.00	0.02
11	7.00	0.23	0.22	0.20	-0.01	0.03
12	7.20	0.24	0.24	0.22	0.00	0.02
13	8.06	0.29	0.26	0.24	-0.03	0.05
14	8.12	0.29	0.28	0.26	-0.01	0.03
15	8.62	0.33	0.30	0.28	-0.03	0.05
16	8.91	0.34	0.32	0.30	-0.02	0.04
17	8.99	0.35	0.34	0.32	-0.01	0.03
18	9.63	0.39	0.36	0.34	-0.03	0.05
19	9.71	0.40	0.38	0.36	-0.02	0.04
20	9.83	0.40	0.40	0.38	0.00	0.02
21	9.93	0.41	0.42	0.40	0.01	0.01
22	10.12	0.42	0.44	0.42	0.02	0.00
23	10.38	0.44	0.46	0.44	0.02	0.00
24	10.88	0.47	0.48	0.46	0.01	0.01
25	10.89	0.47	0.50	0.48	0.03	-0.01
26	11.11	0.49	0.52	0.50	0.03	-0.01
27	11.42	0.51	0.54	0.52	0.03	-0.01
28	11.58	0.52	0.56	0.54	0.04	-0.02
29	12.10	0.55	0.58	0.56	0.03	-0.01
30	12.14	0.55	0.60	0.58	0.05	-0.03
31	12.16	0.55	0.62	0.60	0.07	-0.05
32	12.46	0.57	0.64	0.62	0.07	-0.05
33	12.62	0.58	0.66	0.64	0.08	-0.06

34	12.90	0.60	0.68	0.66	0.08	-0.06
35	13.23	0.62	0.70	0.68	0.08	-0.06
36	13.76	0.65	0.72	0.70	0.07	-0.05
37	14.02	0.66	0.74	0.72	0.08	-0.06
38	14.09	0.67	0.76	0.74	0.09	-0.07
39	14.58	0.69	0.78	0.76	0.09	-0.07
40	14.90	0.71	0.80	0.78	0.09	-0.07
41	15.38	0.73	0.82	0.80	0.09	-0.07
42	16.16	0.77	0.84	0.82	0.07	-0.05
43	16.20	0.77	0.86	0.84	0.09	-0.07
44	16.30	0.77	0.88	0.86	0.11	-0.09
45	18.73	0.86	0.90	0.88	0.04	-0.02
46	18.85	0.87	0.92	0.90	0.05	-0.03
47	19.48	0.88	0.94	0.92	0.06	-0.04
48	21.49	0.93	0.96	0.94	0.03	-0.01
49	25.76	0.98	0.98	0.96	0.00	0.02
50	50.08	1.00	1.00	0.98	0.00	0.02

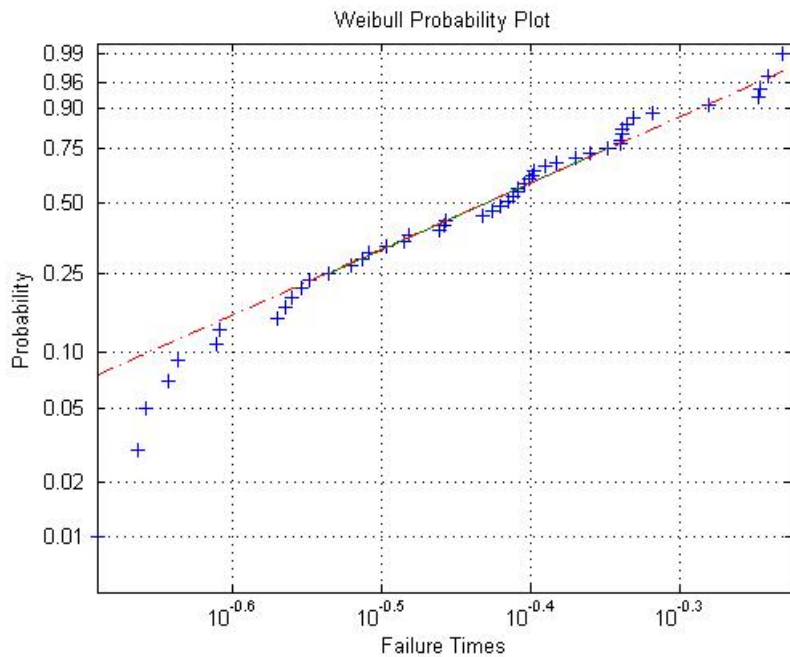

**Figure 5.1:** Failure Times Plot for Weibull Distribution (0.41, 4.26)

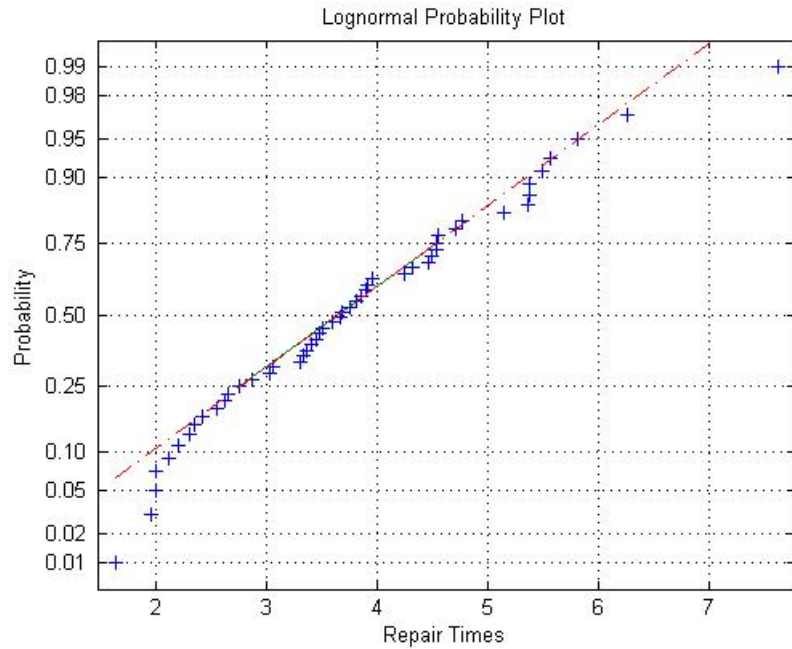

**Figure 5.2:** Repair Times Plot for Lognormal Distribution (0.353, 1.26)

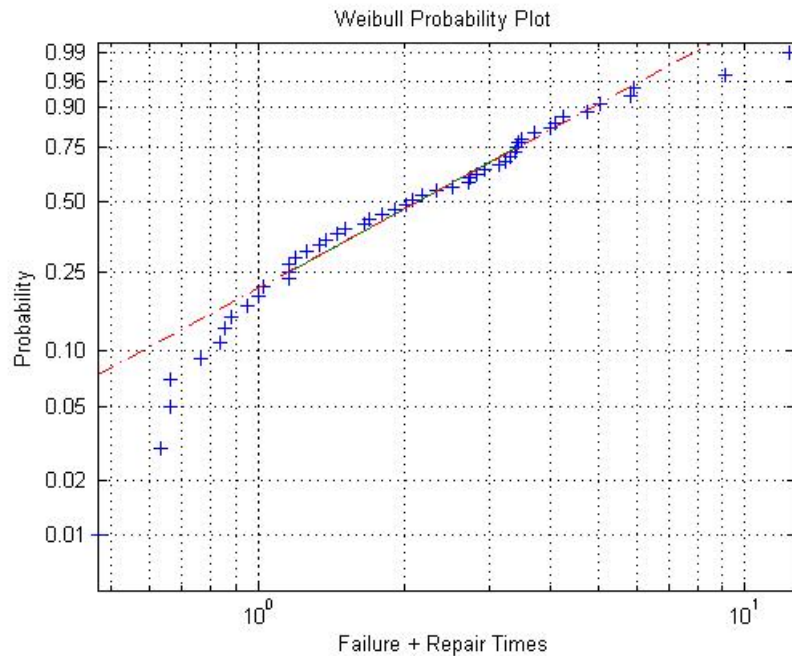

**Figure 5.3:** Resultant Failure + Repair Plot

## 5.2 Transient State Preventive Replacement Model

For maintenance modeling of any system it is most important to determine the optimal replacement interval for each component. The optimal replacement interval is the interval for

which the maintenance cost incurred is optimum. As discussed earlier, renewal theory is used to derive the closed form recursive integral equation 4.9 that is used to compute the optimal replacement interval. The composite trapezoidal rule and surface monitoring technique are used to obtain the optimal solution [16].

The study of individual components reveal that the value of cost function  $C(T, t_A)$  for the age replacement policy decreases very sharply for small value of  $t_A$ . After reaching a certain value, which is the optimal point, the cost function reverts and starts to increase. As  $t_A$  increases, the cost function drops toward the end of the planning horizon. Figure 5.4 illustrates the cost function for four components for different cost structures, where the planning horizon is  $T = 5$  years.

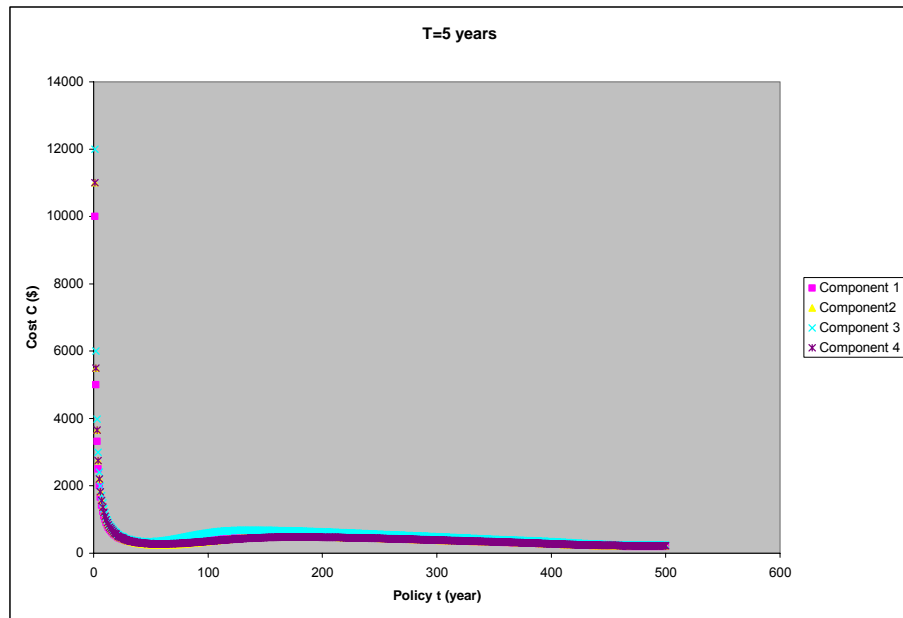

**Figure 5.4:** Cost Structure for Components of the System

The cost function curve for all the four components is very similar in shape. This is because for specific planning horizon, the cost function for different cost structures, namely different  $C_C$  (cost due to CM) and  $C_P$  (cost due to PM) are similar. Table 5.4 demonstrates the

cost structure and the optimal maintenance interval  $t^*$  for all four components of the system for finite planning horizon  $T = 5$  years.

**Table 5.4:** Optimal Preventive Maintenance Interval for the Components (T = 5 Years)

	Machine	Shape ( $\beta_R$ )	Scale ( $1/\alpha_R$ )	$C_C$ (\$)	$C_P$ (\$)	$t^*$ (years)	$C^*(T, t^*)$ (\$)
1	Soaking E WBF	1.002	0.331	100	20	0.52	288.49
2	112" MILL E COIL	0.901	0.26	110	22	0.58	241.97
3	112" MILL E TRIMMER	1.123	0.27	120	24	0.47	333.38
4	112" MILL E HORN	0.89	0.319	110	22	0.58	268.76

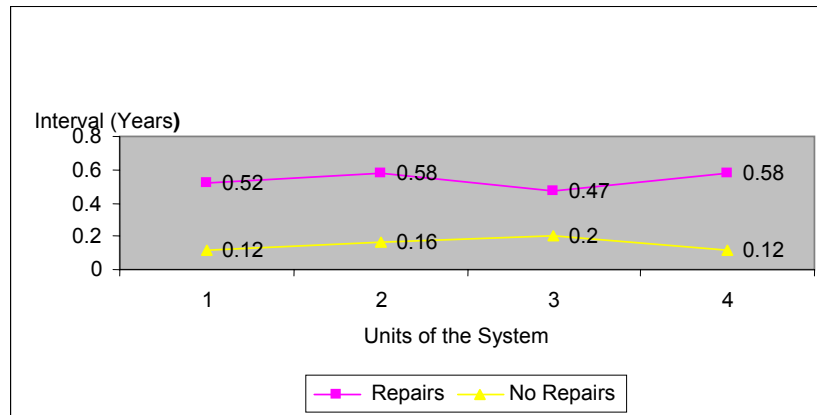

**Figure 5.5:** Optimal Replacement Intervals for the Components of the System

These optimal preventive intervals will be used in the next section to model Preventive and Opportunistic maintenance policies.

### 5.3 Maintenance Model

Using the simulation models developed for preventive maintenance policy (PMP) and opportunistic maintenance policy (OMP) in chapter 4, the resultant parameters estimated in section 5.1 and the optimal preventive interval in section 5.2, the cost of the system is compared for PMP and OMP. In the following section this comparison will be illustrated with the help of an example.

### 5.3.1 Preventive Maintenance Policy

Simulation is used to estimate the total preventive maintenance cost of the system for the finite planning horizon comprising of four components with a planning horizon of 5 years was used for this research. The cost parameters for different cost components namely, CM cost ( $C_C$ ), PM cost ( $C_P$ ) and fixed maintenance cost ( $C_F$ ) is assumed. These parameters are used to compute the optimal replacement age for the four components. According to the maintenance policy, if the component fails before reaching its optimal replacement age, CM is initiated and a cost  $C_C$  is incurred. If the components survive until their optimal replacement age, then PM is initiated and cost  $C_P$  is incurred. Each time CM or PM is carried out, the system incurs a fixed cost  $C_F$ . This procedure is repeated until the finite planning horizon is traversed and then the total maintenance cost is computed. Results of the PMP model are shown in Table 5.5. Table 5.6 gives the average cost and its 95% confidence interval for 100 iterations of system simulation.

**Table 5.5:** Preventive Maintenance Policy (T = 5 Years)

	Machine	$C_C$ (\$)	$C_P$ (\$)	$C_F$ (\$)	Total (\$)
1	Soaking E WBF	100	20	30	216,043
2	112" MILL E COIL	110	22	30	278,755
3	112" MILL E TRIMMER	120	24	30	299,186
4	112" MILL E HORN	110	22	30	234,093
	Total system cost				1,028,077

**Table 5.6:** 95 % Confidence Interval for the Total Cost

	Machine	Average System Cost(\$)	Standard Deviation	CI 95 %
1	Soaking E WBF	216,043	4606	903
2	112" MILL E COIL	278,755	6653	1304
3	112" MILL E TRIMMER	299,186	5962	1168
4	112" MILL E HORN	234,093	5853	1147
	Total System Cost	1,028,076	11997	2351

### 5.3.2 Opportunistic Maintenance Policy

When the system is operating under opportunistic maintenance (OM) two or more components of the system are replaced if they have exceeded their time interval and preventive



maintenance is being performed on another component of the system at the same time. It is assumed that the OM interval is a fraction (for example  $\frac{3}{4}^{\text{th}}$ ) of the preventive replacement interval. During OM, the system incurs a marginal cost of  $C_O$ , but does not incur the fixed cost  $C_F$ . This maintenance procedure is repeated until the finite planning horizon is reached, at which time the total maintenance cost is computed. The results of the OMP model are illustrated in table 5.7. Table 5.8 contains the average cost and its 95% confidence interval for 100 iterations of system simulation.

**Table 5.7: Opportunistic Maintenance Policy (T = 5 Years)**

	Machine	$C_C$ (\$)	$C_P$ (\$)	$C_F$ (\$)	$C_O$ (\$)	Total (\$)
1	Soaking E WBF	100	20	30	6.67	185,035
2	112" MILL E COIL	110	22	30	7.33	246,547
3	112" MILL E TRIMMER	120	24	30	8	280,239
4	112" MILL E HORN	110	22	30	7.33	208,181
	Total					920,001

**Table 5.8: 95 % Confidence Interval for the Total Cost**

	Machine	Average (\$)	Standard Deviation	CI 95 %
1	Soaking E WBF	185,035	4984	977
2	112" MILL E COIL	246,547	6653	1304
3	112" MILL E TRIMMER	280,239	6728	1319
4	112" MILL E HORN	208,181	6795	1332
	Total System Cost	920,001	11434	2241

### 5.3.3 Cost Comparison between PMP and OMP

Table 5.9 demonstrates the cost comparison between PMP and OMP model. Clearly it can be observed that the OMP is more economical than PMP by 11%. This is intuitive as during opportunistic maintenance the high fixed cost of maintenance is obviated as maintenance is carried out on two or more components at the same time.

**Table 5.9: Cost Comparison between PMP and OMP**

POLICY	DESCRIPTION	SYSTEM COST
PMP	Preventive Maintenance Policy	\$1,028,076
OMP	Opportunistic Maintenance Policy	\$920,001

Though it is observed that OMP model is more economical than PMP model, the optimal replacement times for individual units might not be the optimal replacement times for the whole system. To observe how total system costs vary as a result of changes in optimal replacement intervals, sensitivity analysis is performed by perturbing the optimal replacement time intervals for each of the four components.

### 5.3.4 Sensitivity Analysis

Sensitivity analyses are important for investigating the effect on the optimal solution provided by the simulation results [16]. The objective of doing a sensitivity analyses is to explore the robustness of the system parameters with small changes or perturbations around the mean values.

The results of the sensitivity analyses for PMP and OMP models are presented in Tables 5.10 and 5.11. A comparison between the two models is presented in Table 5.12.

**Table 5.10:** Sensitivity Analysis on Optimal Replacement Interval for PMP

Interval (Years)	1	2	3	4	Total (\$)	Percentage Increase
- 0.4	\$371,920	\$392,700	\$372,714	\$341,140	\$1,478,474	22.46%
- 0.2	\$247,380	\$310,340	\$322,296	\$262,196	\$1,142,212	9.99%
Optimal	\$216,043	\$278,755	\$299,186	\$234,093	\$1,028,076	---
+ 0.2	\$216,600	\$279,328	\$305,260	\$257,600	\$1,058,788	2.90%
+ 0.4	\$234,250	\$288,008	\$334,672	\$266,988	\$1,123,918	14.53%

**Table 5.11:** Sensitivity Analysis on Optimal Replacement Interval for OMP

Interval (Years)	1	2	3	4	Total (\$)	Percentage Increase
- 0.4	\$320,350	\$280,600	\$292,550	\$260,850	\$1,154,350	20.30%
- 0.2	\$198,670	\$238,630	\$302,550	\$221,980	\$961,830	4.35%
Optimal	\$185,035	\$246,547	\$280,239	\$208,181	\$920,002	---
+ 0.2	\$186,110	\$251,540	\$282,780	\$213,150	\$933,580	1.45%
+ 0.4	\$218,080	\$279,090	\$312,110	\$243,930	\$1,053,210	12.65%

**Table 5.12:** Comparison between PMP and OMP

Interval (Years)	Total System Cost			
	PMP	OMP	Difference	Percentage
- 0.4	\$1,478,474	\$1,154,350	\$324,124	22%
- 0.2	\$1,142,212	\$961,830	\$180,382	16%
Optimal	\$1,028,076	\$920,002	\$108,074	11%
+ 0.2	\$1,058,788	\$933,580	\$125,208	12%
+ 0.4	\$1,123,918	\$1,053,210	\$70,708	6%

From table 5.10 and table 5.11, it can be observed that when the optimal replacement interval for individual components is decreased by 0.2 year the overall system cost increases by 20%. For example, the optimal replacement interval for component 1 is 0.52 years, if we decrease this optimal interval to 0.32 years, the total maintenance cost of the system increases by 10%. When the optimal replacement interval for individual components is decreased by 0.4 years the total maintenance cost of the system increases to about 20%. This is intuitive because as optimal replacement interval for individual units is decreased there are frequent replacements due to PM. Similarly, when the optimal replacement interval for the component is increased by 0.2 years, the overall cost of the system increases by 3% and when the interval is increased by 0.4 year the overall system maintenance cost increases by 15%. This is due to the fact that there are more frequent CM procedures in the system.

It can be observed from table 5.12 that when the optimal interval for individual components is decreased, the difference between the system cost in PMP and OMP model is much more pronounced as compared to when the optimal interval is increased. This is intuitive since an increase in the optimal interval will result in more maintenance cost due to CM while on the other hand a decrease in the optimal interval maintenance will result in increased cost due to PM (opportunistic maintenance is done only during PM).

#### **5.4 Availability Analysis**

As discussed earlier availability is a key performance measure and a vital design criterion for any maintained system. Instantaneous availability also known as transient state availability for

the individual components of the system is calculated. Instantaneous availability for the individual components is then compared with the maintenance cost as shown in figure 5.6 for component 1. It is important for designing purpose to compare availability with the cost because different organizations have varied importance with respect to cost and availability, for example while designing a space shuttle more emphasis is placed on availability and not on cost. Hence a comparison of cost versus availability is essential and has been incorporated in this thesis. Figure 5.6 is a 3-D plot of instantaneous availability versus cost during different replacement intervals.

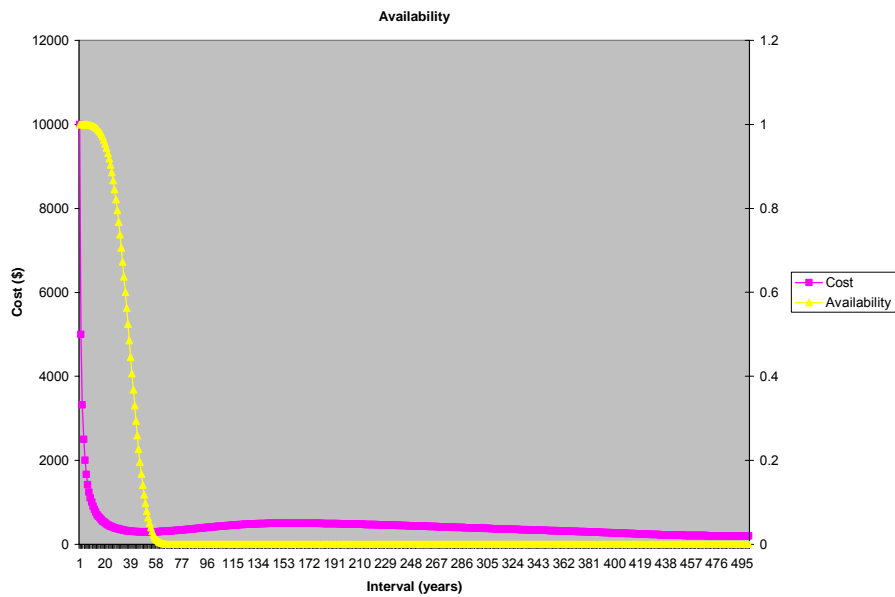

**Figure 5.6:** Comparison between Cost and Availability with Interval Width

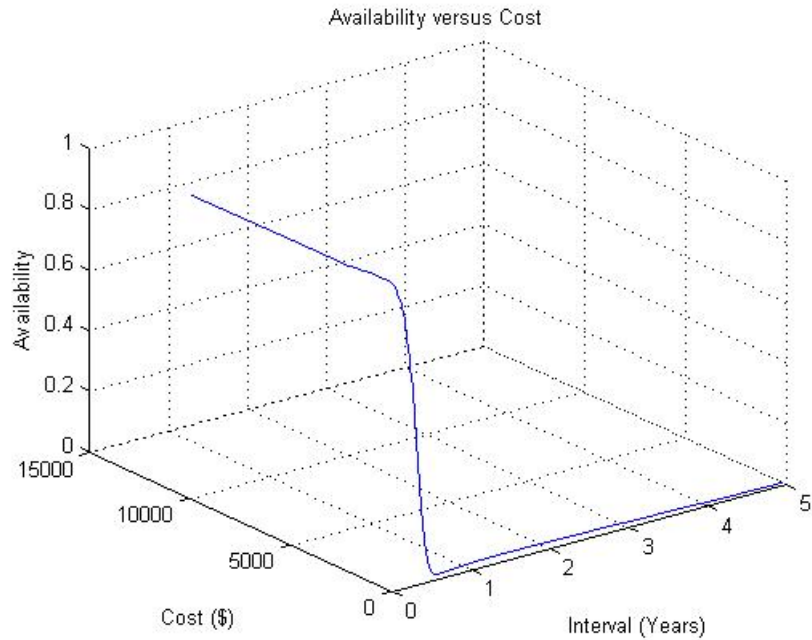

**Figure 5.7:** 3-D Plot of Availability versus Cost

From figure 5.6 and 5.7 it is clear that to attain high availability the maintenance interval of the components should be as low as possible. If the maintenance interval is less than optimal the maintenance cost of the system will increase. Hence availability and cost should be considered two different designing criteria.

## Chapter 6. Conclusions and Future Research

The objective of this research was to realistically analyze multi unit system characterized by IFR behavior and taking into account the effects of opportunistic maintenance and the transient state of the system. The OM model was developed for a four component system and was compared with the preventive maintenance model. Transient state availability was also computed as a performance measure and a key design creation for maintained systems. Simulation was used to compare the system maintenance cost for OM and PM models.

A transient state age replacement equation was developed using renewal theory. The age replacement equation is used to compute the optimal replacement age for the four individual components. One main assumption in the past research has been that the repair or maintenance times are negligible, but in reality it is never possible. In this thesis failure times were assumed to follow the Weibull distribution and repairs or maintenance times were assumed to follow the lognormal distribution. A real life Aluminum Hot Roll line example was used to evaluate the OM and PM models. Four critical components out of 30 were considered with IFR behavior. A finite time horizon of 5 years was considered. Resultant joint probability distribution was estimated and proved using the K-S test. The optimal replacement times of the individual components were computed using transient state age replacement equation. The system maintenance cost of the OM and PM models were compared. From the results it was observed that:

1. The resultant Weibull + lognormal distribution for the four components was a Weibull distribution.

2. The optimal replacement times of the individual components were 0.42, 0.58, 0.47 and 0.58 years respectively.
3. OM model was 11% more economical than PM model for finite planning horizon of 5 years.
4. The transient state availability was compared with the cost for different maintenance intervals. A 3-D graph was also plotted.

Sensitivity analysis was performed to explore the robustness of the system parameters by varying the optimal replacement intervals for individual components. The results from the sensitivity analysis indicated that the optimal maintenance intervals for individual components were sensitive to the change in the total system maintenance cost. The total system maintenance cost was lowest at optimal maintenance intervals for individual components.

### **6.1 Future Research Direction**

1. In this research we developed an opportunistic maintenance policy of a multi unit system assuming stochastic independence between the units of the system. However this may not be practical because when there is always some kind of stochastic dependence between the units of the system. Therefore research into the problem of stochastic dependence must be explored.
2. Although it was assumed that opportunistic maintenance interval was a fraction of preventive maintenance interval, this OM interval might not be the optimal interval for the system. In that case analytical formulations must be used to compute the optimal OM interval.

## REFERENCES

- [1] Barlow, R.E. and Hunter, L. *Optimal Preventive Maintenance Policies*, Operations Research, Vol. 8, pp. 90-100, 1960
- [2] Barlow, R.E., and Proschan, F., Comparisons of Replacement Policies, and Renewal Theory Implications, The Annals of Mathematical Statistics, Vol. 35, pp. 577-589, 1964
- [3] Chan, L.Y., Mui, L.M. and Woo, M.C., *Reliability Analysis and Maintenance Policy of Radiators For a large Fleet of Buses*, Quality and Reliability Engineering International, Vol. 13, pp. 117-126, 1998
- [4] Cox, D.R., *Renewal Theory*, London: Methuen & Co Ltd., 1962
- [5] Huang, J. *Preventive Maintenance Program Development for Multi-unit System with Economic Dependency- Stochastic modeling and Simulation Study*, Ph.D. Dissertation, University of South Florida, Tampa, 1993
- [6] Hui, Y. and Wang, X., *The Reliability and Performability of a Repairable and Degradable ATP System*, IEEE Transactions on Reliability, Vol. 3, No. 28, pp. 1609-1612, 1996
- [7] Internet Website URL: <http://www.weibull.com/>, Reliability Engineering and Life Data Analysis Resources
- [8] Jacobson, D.W. and Arora, S.R., *A Nonexponential Approach to Availability Modeling*, Reliability and Maintainability Symposium, IEEE Proceedings, pp. 253-260, Jan, 1995
- [9] Keats, J.B. and Chambal, S.P., *Transient Behavior of Time-Between-Failures of Complex Repairable Systems*, National Meeting for the Institute of Operations Research and Management Science, San Antonio, TX, November, 2000
- [10] Lewis, E.E, *Introduction to Reliability Engineering*, 2<sup>nd</sup> Edition, John Wiley and Sons, Inc, New York, 1996
- [11] Mann, L., *Maintenance Management*, Lexiton Books, Lexiton, pp. 97-140, 1976
- [12] Mc Call, J.J. *Maintenance Policies for Stochastically Failing Equipment: A Survey*. Management Science, Vol. 11, pp. 493-524, 1965
- [13] Murdock, Jr. W.P., *Component Availability of an Age Replacement Preventive Maintenance Policy*, Ph.D. Dissertation, Department of Industrial and Systems Engineering, Virginia Tech, 1995



- [14]Narahari, Y. and Viswanadham, N., *Transient analysis of Manufacturing Systems Performance*, IEEE Transactions on Robotics and Automation, Vol. 10, No 2, pp. 230-244, 1994
- [15]Noortwijk, J.M., Dekker, R., Cook, T.A., *Expert Judgment in Maintenance Optimization*, IEEE Transactions on Reliability, Vol. 41, No 3, pp. 427-432, 1992
- [16]Okogbaa, O.G. and Peng, X., *Loss Function of Age Replacement Policy for IFR Unit Under Transient Response*, The 1997 Design and manufacturing Grantee Conference, Seattle, WA, Jan. 7-10, 1997
- [17]Okogbaa, O.G., Shell, R., *Development of Predictive Maintenance Program*, tech. Report, PR010/10/87MI, Univ. of Cincinnati, Kaiser Aluminum Co, Ravenswood, WV, 110 pages, Oct. 1988
- [18]Peng, X. *Preventive Maintenance and Opportunistic Maintenance Planning for Transient Multiunit Systems*, Ph.D. Dissertation, University of South Florida, Tampa, Florida, 1998
- [19]Ross, S.M., *Introduction to Probability Models*, Academic Press, Boston, 1989
- [20]Rupe, J. and Kuo, W., *Solution to a Modified Tool Loading Problem for a Single FMM*, International Journal of Production Research, Vol. 35, No. 8, pp. 2253-2268, 1997
- [21]Saches, N.W., *What Does 'PM' Really Mean? Preventive vs Predictive Maintenance*, Lubrication Engineering, November, pp. 889-891, 1991
- [22]Sampath, V. *Time series intervention analysis of multi-unit IFR systems for maintenance management*, Masters of Science Thesis, University of South Florida, Tampa, Florida, 2003
- [23]Sethi, D.P.S., *Opportunistic Replacement Policies*, in: Tsokos, C.P. and Shimi, I.N. (Ed), *The Theory and Application of Reliability*, Vol. 1, pp. 433-447, Academic Press, New York, 1977
- [24]Seward, L, *Preventive maintenance for a multi-task system*, Ph. D. Dissertation, Virginia Polytechnic Institute and State University, Virginia, 1998
- [25]Scheaffer, R.L. and McClave, J.T., *Probability and Statistics for Engineers*, Duxbury Press, California, 1995
- [26]Sun, H. and Han, J.J., *Instantaneous Availability and Interval Availability for System with Time Varying Failure Rate: Stair Step Approximation*, 2001 Pacific Rim International Symposium, IEEE Proceedings, pp. 371-374, Dec. 2001
- [27]Sun, H. and Han, J.J., *The Failure of MTTF in Availability Evaluation, Reliability and Maintainability Symposium*, IEEE Proceedings, pp. 279-284, Jan 2002
- [28]Vaidyanathan, K., Selvamuthu, D. and Trivedi, K.S., *Analysis of Inspection-Based Preventive Maintenance in Operational Software Systems*, Intl. Symposium on Reliable Distributed Systems, SRDS 2002, Osaka, Japan, October 2002
- [29]Valdez-Flores, C. and Feldman, R.M., *A Survey of Preventive Maintenance Models for Stochastically Deteriorating Single-Unit Systems*, Naval Research Logistics, Vol. 36, pp. 419-446, 1989

- [30] Vermuelen, S.T.J.A, Rijanto, H. and Schouten , F.A, *Modeling the Influence of Preventive Maintenance on Protection System Reliability Performance*, IEEE Transactions on Power Delivery, Vol. 13(4), pp. 1027-1032, 1998
- [31] Wang, H. *A Survey of Maintenance Policies of Deteriorating Systems*. European Journal of Operations Research, Vol. 139, pp. 469-489, 2002
- [32] Wang, W. and Christer, A.H., *A Modeling Procedure to Optimize Component Inspection Over A Finite Time Horizon*, Quality and Reliability Engineering International, Vol. 13, pp. 217-224, 1997
- [33] Zheng, X. and Fard, N., *A Maintenance Policy for Repairable Systems based on Opportunistic Failure-rate Tolerance*, IEEE Transactions on Reliability, Vol. 40, pp. 237-244, 1991